

# OPERATING INSTRUCTIONS AND SAFETY NOTES

## Accu Grease Gun

with Accessories



## **Pressol Schmiergeräte GmbH**

This documentation is exclusively intended for the operating company and their staff.

Without our written consent, the content of this documentation (textes, figures, drawings, charts, diagrams etc. ), must not be duplicated or distributed, neither in full or in part, utilized for the purpose of competition or passed on/made available to third parties.

### **Pressol Schmiergeräte GmbH**

Parkstraße 7

93167 Falkenstein | Germany

Tel. +49 9462 17-0

Fax +49 9462 17-208

info@pressol.com

www.pressol.com

### **Operating instructions translation**

Date of issue: 08/2018

We reserve the right to make design and product modifications, which serve to improve the product.

## **Table of Contents**

1.	Introduction	3
1.1	Preface	3
1.2	Obligations of the personnel	3
1.3	Symbols in this manual	3
1.3.1.	Structure of the safety notes	3
1.3.2.	Hazard symbols	4
1.3.3.	General symbols	4
2.	Safety notes	4
3.	Intended conditions of use	4
3.1	Reasonably foreseeable misuse	5
3.2	Design and functional description	5
4.	Technical data	6
5.	Area of application	6
6.	Risks when handling the grease gun	6
7.	Commissioning and putting into operation	7
7.1	Filling the grease gun	7
7.1.1.	Filling with grease cartridge according to DIN 1284	7
7.1.2.	Filling with grease gun filling device	8
7.1.3.	Filling the grease gun from a bulk container	8
7.1.4.	Removal of trapped air	8
7.2	Making the grease gun ready for operation	8
8.	Accu	9
8.1	Safety instructions when handling the accu	10
9.	Operation	10
10.	Inspection, maintenance and cleaning	11
11.	Troubleshooting	11
12.	Exploded view of the accu grease gun	12
13.	Accu charger for Li-Io accu 20 V	13
14.	Safety instructions for the accu charger	13
15.	Repair / Service	14
16.	Disposal	14
17.	Transport	14
18.	EC Declaration of Conformity	15

## 1. Introduction

### 1.1 Preface

**Please carefully read these operating instructions and observe in particular all safety notes!**

Our staff will be pleased to provide support if you have any questions about the product.

**Yours sincerely, Pressol Schmiergeräte GmbH**

### 1.2 Obligations of the personnel

Before commencing work, all persons who are entrusted to work with the accu grease gun are obliged:

- to follow all applicable regulations on occupational safety and accident prevention.
- to read and to comply with all safety instructions and warning notes contained in these operating instructions.

Please observe the following instructions in the interest of all concerned:

- Refrain from any unsafe working methods!
- Adhere to all hazard and warning notes contained in this manual!
- In addition to this documentation, keep to all generally accepted safety rules, legal provisions as well as all other binding rules regarding occupational safety, accident prevention and environmental protection!
- Wear appropriate protective clothing in accordance with the work to be done!
- Perform only work for which you have been sufficiently trained and instructed!
- Only genuine spare parts as well as original tools and auxiliaries of the manufacturer are allowed to be used in order to ensure the functional safety and maintain the warranty coverage.

### 1.3 Symbols in this manual

#### 1.3.1 Structure of the safety notes

The safety notes have the following structure:



#### **SIGNAL WORD**

##### **Type and source of the hazard**

- Consequences of non-compliance with the notes
- Measures to avoid that risk

Depending on the danger level, different signal words are used:

Signal word	Danger level	Consequences of non-compliance
<b>DANGER</b>	Imminent threat of danger	Death or serious bodily injury
<b>WARNING</b>	Possible threat of danger	Death or serious bodily injury
<b>CAUTION</b>	Possibly dangerous situation	Minor bodily injury
<b>ATTENTION</b>	Possibly dangerous situation	Damage to material property



**NOTE**

Indicates further information or tips which facilitate work.

---

**1.3.2 Hazard symbols**

<b>Symbol</b>	<b>Meaning</b>
	General hazard symbol. The warning note marked in this way contains supplementary information on the type of hazard.
	This symbol warns of dangerous electrical voltages.
	This symbol warns of a hazardous explosive atmosphere.

**1.3.3 General symbols**

<b>Symbol</b>	<b>Meaning</b>
■	A small black square indicates the work you have to perform.
–	The arrow identifies cross-references.
⇒	The arrow identifies cross-references. If cross-references to other chapters are required within the text, the expression is shortened for reasons of clarity. Example: ⇒Chapter 2 Safety instructions This means: please refer to chapter 2 for the safety instructions.

**2. Safety instructions**

Various dangers may occur if the accu grease gun is improperly handled during installation, commissioning and daily operation.



**WARNING**

**Risk of injury and damage to material property because of improper handling!**

- Hold the manual at the disposal of the operating staff at the usage site of the unit.
  - Country-specific safety measures and accident prevention regulations must be observed.
- 

**3. Intended conditions of use**

The accu grease gun is ideally suited for mobile applications and is solely designed for pumping greases up to NLGI 2. Operation with 20 Volt accu power.

The maximum permissible technical data must not be exceeded.

Any departure from the usage stipulations (other media, use of force) or unauthorized modifications (changes, use of non-original parts) can be dangerous and are considered to be non-intended usage.

---

The user is liable for any damage resulting from non-intended use.

## 3.1 Reasonably foreseeable misuse

Foreseeable misuse could be:

- Using the battery grease gun with a cartridge that is not conform to the DIN 1284 standard.
- Use greases that do not comply with the NLGI 2 viscosity class.

## 3.2 Design and functional description

The grease gun tube is equipped with a spring-loaded forming collar to aid in the conveyance of fat.

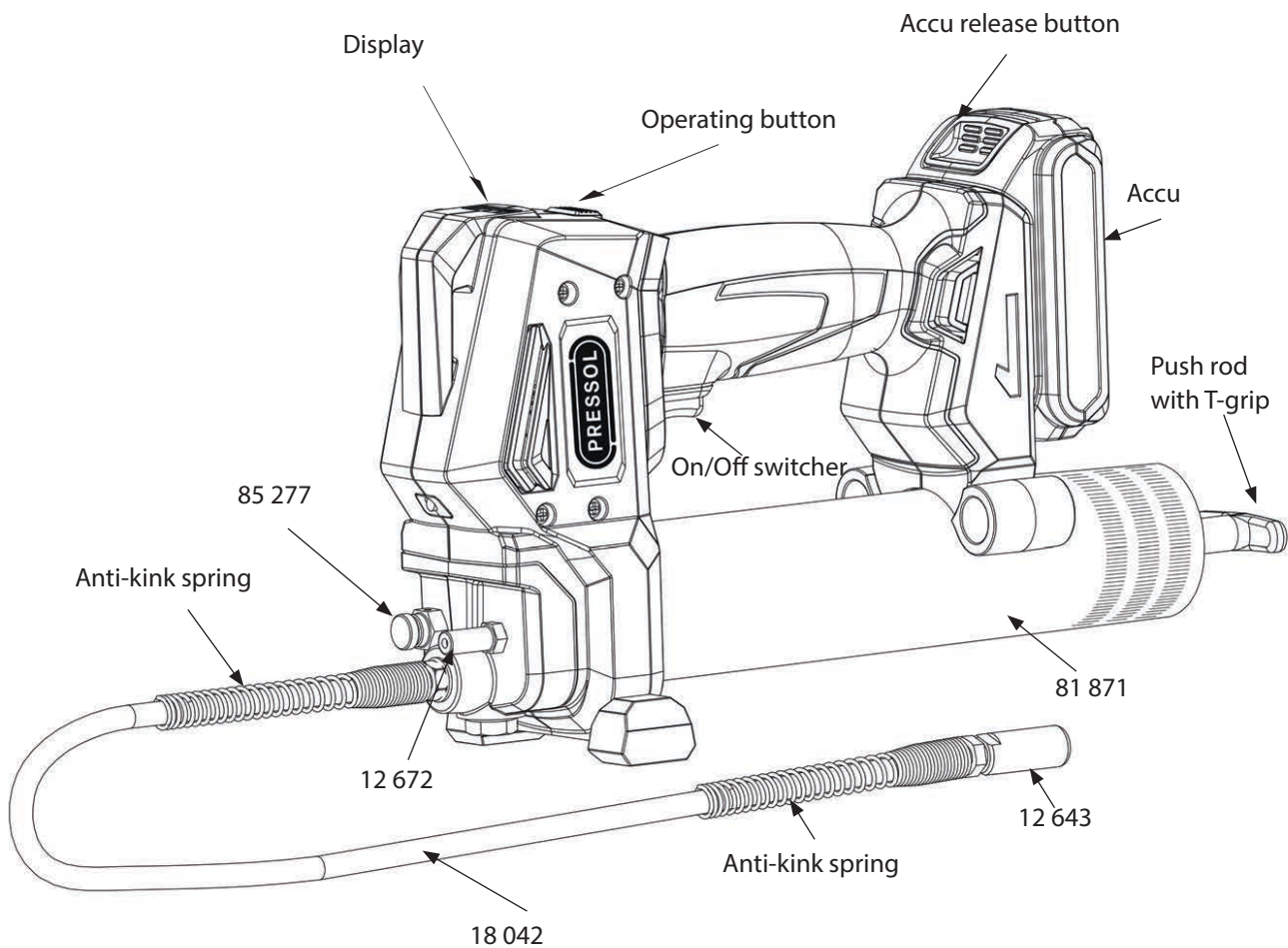

Fig. 3.2 -1: Structure accu grease gun

## Spare parts list

Item no.	Designation	Item no.	Designation
18 042	Flexible high-pressure hose	81 871	Grease gun tube complete
18 051 100	Li-Io-Accu 20V, 2000 mAh	85 277	Venting valve
18 051 101	Li-Io-Accu 20V, 4000 mAh	00 442	Flat gasket for grease gun head
18 051 200	Charger - 230 V	12 643	Precision machined coupler
12 672	Filling nipple		

## 4. Technical data

Description	Accu grease gun Li-Io 20 V 18 051
<b>Grease gun</b>	
Grease gun pump actuation	continuous grease supply provided by 20 V electric motor
Refilling options	400-g-grease cartridge DIN 1284 or bulk grease
Grease supply into the grease gun head	spring operated
Diameter of grease pump piston (mm)	7
Delivery rate (g/min)	approx. 150
Operating pressure max. (bar)	400
Maximum pressure (bar)	680
Airborne emissions	< 70 db(A)
Grease supply hose (mm)	11 x 1000
Operation of plunger rod	with T-grip
Sealing cover	loose
Wall thickness of grease gun tube (mm)	1
Dimensions LxWxH (mm)	380 x 205 x 110
Weight, accu grease gun empty (kg)	3,07
<b>Charger for Li-Io-Accu 20 V</b>	
<b>Charger 18 051 200</b>	
Input voltage	230 V/AC
Frequency (Hz)	50/60
Power(W)	45
Output voltage	16 - 21 V/DC
Nominal current	1,5 A
Dimensions without cable LxWxH (mm)	180 x 120 x 85
Weight (kg)	0,455
Power cable with Euro plug, length (m)	1,6
<b>Accu</b>	
<b>Li-Io-Accu 20 V 18 051 100</b>	
Capacity	2000 mAh
Voltage (V)	20
Charging time accu (minutes)	approx. 60
Delivery/accu charge	25 pieces 400 g cartridges (without counter pressure) 7 pieces 400 g cartridges (at approx.100 bar counter pressure)
Dimensions LxWxH (mm)	118 x 76 x 45
Weight (kg)	0,378
<b>Accu</b>	
<b>Li-Io-Accu 20 V 18 051 101</b>	
Capacity	4000 mAh
Voltage (V)	20
Charging time (minutes)	approx. 120
Delivery/Accu load	50 pieces 400 g cartridges (without counter pressure) 15 pieces 400 g cartridges (at approx. 100 bar counter pressure)
Dimensions LxWxH (mm)	118 x 76 x 65
Weight (kg)	0,632

Tab. 4.-1: Technical data

## 5. Area of application

The grease gun is suitable for pressing greases up to the viscosity class NLGI 2 at a temperature of 20 °C.

## 6. Risks when handling the accu grease gun



### CAUTION

**Excessive pressure at the point of lubrication may destroy the grease nipple, the bearing or even the machine**

- Observe the maintenance and service instructions of the machine manufacturer.



### CAUTION

**Damaged accessories may lead to personal injury and material damage!**

- High pressure hoses must not be bent, twisted or stretched.
- Attachments and accessories must be checked for wear, splits or other damage throughout its period of use.
- Damaged accessories and attachments must be replaced immediately.



### DANGER

- Never work with the accu grease gun in the vicinity of open fire, gas or other combustible fluids.
- The accu grease gun can build up a high pressure (up to 400 bar). Safety glasses and safety shoes are required. Keep hands away from rubber hoses under high pressure.



### CAUTION

**Risk of personal injury due to electric shock!**

- Avoid contact with other metals during greasing because of the risk of accidental earthing.
- Do not use the device in rain or when wet (electric shock!).
- Do not use the accu charger in humid / moist rooms.
- Do not use the grease gun if it is damaged, if it was stored under the open sky or if it was dipped into a liquid.

## 7. Commissioning and putting into operation

- Check the grease gun and the accessories for completeness (see ⇒ chapter 12. exploded view of the accu grease gun).
- After each refilling or grease cartridge change, check the grease gun. Note that an air bubble may cause fat loss or inefficiency.  
Use the venting valve to vent the grease pump (see ⇒ chapter 7.1.4.).

### 7.1 Filling the grease gun

There are various possibilities to fill the grease gun:

- Filling with grease cartridge according to DIN 1284.
- Filling with grease gun filling device by filling nipple.
- Filling with bulk grease from a large container.

## 7.1.1. Filling with grease cartridge according to DIN 1284

### Removing an empty cartridge:



### CAUTION

#### Injuries due to overpressure

- Do not open the grease gun under pressure!
- Before disconnecting the grease gun head and tube, the push rod must be pulled back and locked automatically by the locking pawl.

- 
- Unscrew the grease gun tube from the device.
  - Slowly loosen the handle, pull the grease cartridge up and out of the device.

### Installing a new grease cartridge:

- Remove the plastic cap from the full grease cartridge and insert it into the grease gun tube.
- Only then tear off the „pull-off“ closure of the cartridge and screw up the grease gun head.
- While pulling on the push rod, activate the locking pawl and slide the push rod back into the tube.
- Use the venting valve to bleed off any air that may be trapped in the cartridge (see ⇒ chapter 7.1.4.).



### NOTE

- Ensure cleanliness during installation and that the accessories are correctly connected with the grease gun head.
- Use appropriate sealants and adhesives (e. g. Teflon tape).

## 7.1.2. Filling with grease gun filling device

- Put the grease gun with the filling nipple on the filling valve of the grease gun filling device and hold it with light counter pressure.
- Actuate the grease gun filling device to fill the grease gun. The push rod may be pressed out of the grease gun tube by the filling operation.
- While pulling on the push rod, activate the locking pawl and slide the push rod back into the tube.

## 7.1.3. Filling the grease gun from a bulk container

- Unscrew the grease gun tube from the grease gun.
- Plunge the open end of the grease gun tube into the grease container.
- Hold the grease gun tube and slowly pull the piston back by means of the grip.  
Ensure that the open end of the grease gun tube is always completely immersed in the grease in order to avoid the intake of air.
- Stop filling when the piston is completely pulled out.
- Screw the grease gun tube down again to the head of the grease gun.
- While pulling on the push rod, activate the locking pawl and slide the push rod back into the tube.

## 7.1.4. Removal of trapped air

- Use the venting valve to vent the grease pump.
- Vent the grease gun, open the venting valve until grease escapes from the venting valve.
- Close the venting valve.
- Press the trigger until grease escapes from the precision machined coupler.

## 7.2 Making the grease gun ready for operation

Check to ensure that the grease gun tube is tightly screwed in the device.

To remove trapped air, open the venting valve while the push rod is moved forward.

The grease gun is now ready for operation.



## 8. Accu

The accu is only partially charged at delivery. When used for the first time, it must be fully charged to ensure satisfactory performance. When the tool performance begins to drop sharply, it indicates the accu needs to be recharged.







### NOTE

- **Only use the supplied charger.** Other chargers may catch fire and are not suitable for this device.
- Avoid that the accu is completely discharged when the current level is low, because otherwise the accu's lifetime will be considerably reduced.

### Charging process

- Connect the charger to an appropriate socket before inserting the accu.
- Put the accu on the charger. Check to ensure that the accu and the charger are completely connected. When the accu is fully secured, a faint „click“ can be heard.
- Press the selection button in order to display the charging status on the screen. If the accu is fully charged, the display remains switched on.
- When the accu is completely charged (approx. 60 minutes), disconnect the charger from the mains and take out the accu.



### Accu charging indicators

Accu indicator	Solution
 Slowdown hot/cold accu	Slow or quick flashing Cool the accu (0 °C - 45 °C)
 Accu fault	Quick flashing Replace the accu
 Accu charging	Slow flashing
 Accu fully charged	Steady flashing

### Accu charging status and speed display for grase delivery

1.) When pressing the ON/Off switch, at first the display shows the accu's charging state and then the selected delivery speed.





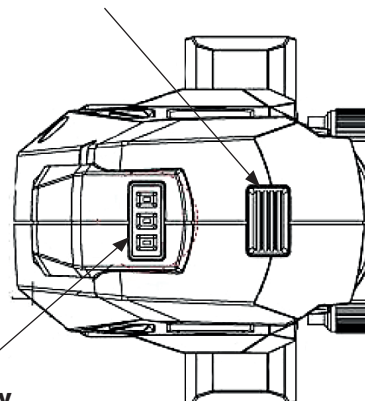

**Selection button**  
for high/slow speed

Display indicator	Meaning
	Full power 100 %
	Enough power 75 %
	Low power 25 %



**Display**  
Accu capacity and speed display

- 2.) Shortly press the selection button to change the speed.

Display indicator	Meaning
  	slow speed, low delivery volume
  	high speed, high delivery volume

The indicator in the middle does not light up in **case 2**.

## 8.1 Safety instructions when handling the accu



### WARNING

#### Risk of injuries by burns!

- **Never throw the accumulator in a fire. Risk of explosion!**
- Never charge defective (leaky) accumulators.
- Never allow the accu to come into contact with water.
- Do not store the accu in places where the temperature may exceed 50 °C.
- Store the accu only at ambient temperatures between 5 °C and 40 °C.
- Do not try to open the accu.
- In case of improper use, fluid may spurt out of the accu. This fluid may cause irritations or burns. Avoid any contact with this fluid. In the event of accidental contact, rinse the affected area with plenty of water. In case of eye contact, flush with water and contact a physician immediately.
- Only use the specified charger to charge the accu. There is a danger of fire if an unsuitable charger is used.
- If the accu is not used, it must be kept away from other metal objects, such as staples, coins, keys, nails and other small metal objects which could make a connection from one pole to the other. A short circuit between the poles may cause burns and fires.
- Store the device in a clean and dry place out of the reach of children.

## 9. Operation



### CAUTION

#### Excessive pressure may lead to a bursting of the grease gun head and of the accessories!

- When using the grease gun, use appropriate equipment such as protective gloves and goggles.
- 
- Put the grease gun with the precision machined coupler on the filling nipple.
  - Carry out the greasing procedure by activating the ON/OFF switcher.

## 10. Inspection, maintenance and cleaning

In general, the accu grease gun only requires very little care or maintenance.

- Inspection, maintenance and cleaning work must be carried out by qualified personnel only.



### CAUTION

#### **Risk of injury**

- Disconnect the charger from the mains before carrying out inspection, maintenance or cleaning work.
- Remove the accu from the device.

- Due to the operator responsibilities the following components must be regularly checked to avoid the risk of environmental or equipment damage or personal injury:

#### **Before each use:**

- Check the general condition of the grease gun.
  - Check all moving parts for possible irregularities.
  - Look out for burst or broken components, a leaking accumulator, damaged hoses as well as for each irregularity which would prevent the grease gun from being safely started.
  - In case of abnormal noises or vibrations, check the grease gun before continuing to use the unit.
  - If required, use a soft and dry cloth to remove dirt and grease residues from the exterior of the grease gun.
- Always store the grease gun with the accumulators removed!
  - Store the device in a clean and dry place out of the reach of children.

## 11. Troubleshooting

Malfunction	Cause	Solution
Motor does not run	▶ No power supply, the accu is empty	▶ Charge the accu
Grease comes out of the vent valve	▶ Blocked lubrication point ▶ Clogged hose	▶ Check discharge hose ▶ Clean or replace the hose
Grease gun does not deliver fat	▶ Air pockets in the grease  ▶ Push rod blocked	▶ Check to ensure that the grease gun tube assy. contains grease. ▶ Repeat the preparation process (⇒ chapter 7) ▶ Removal of trapped air (⇒ chapter 7.1.4.) ▶ Replace the grease gun tube assy.
The accu cannot be charged	▶ The charger is not properly powered ▶ The accu is damaged	▶ Check the power cable connection ▶ Replace the accu

## 12. Exploded view of the accu grease gun

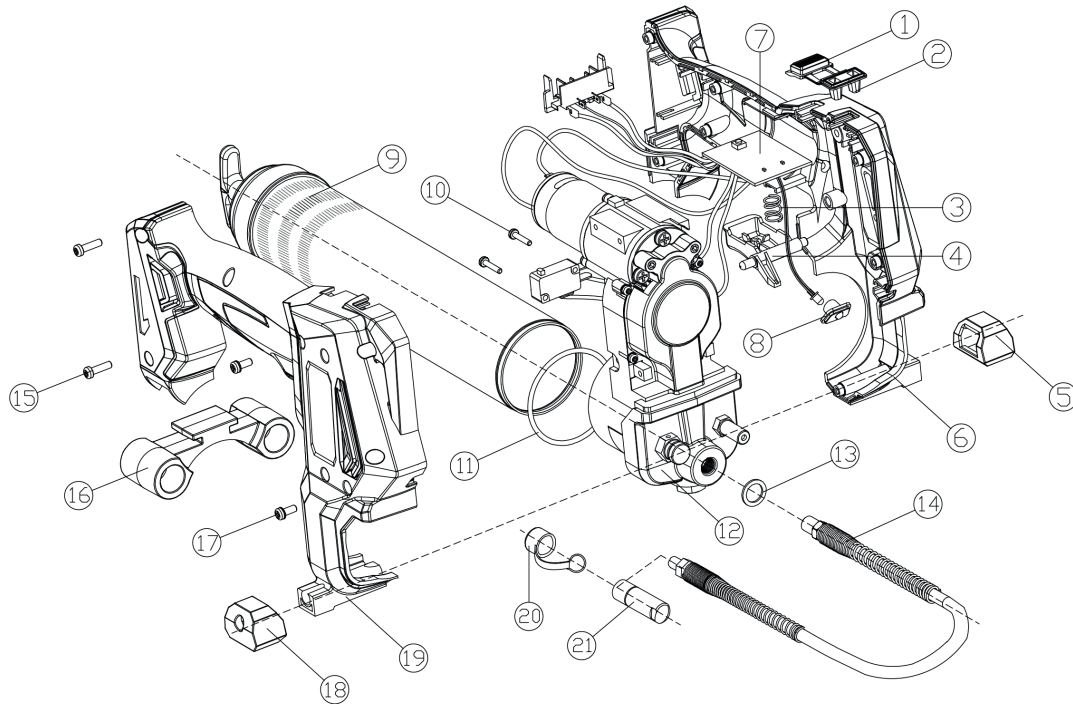
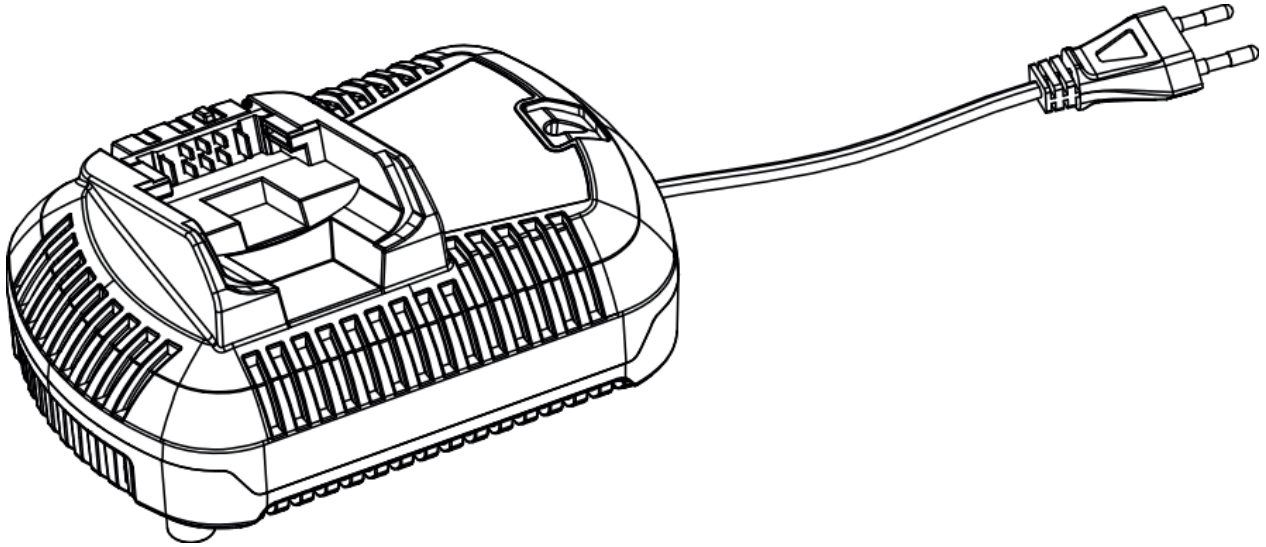

Fig. 12.-1 Exploded view of the accu grease gun

Pos.	Quantity	Description
1	1	Delivery speed selection button
2	1	Power & speed display
3	1	Spring
4	1	On/Off switcher
5	1	Stand (left)
6	1	Housing (left)
7	1	Control panel assembly
8	1	LED light cover
9	1	Grease gun tube assembly
10	2	Cross headed screw
11	1	O ring
12	1	Gear box assembly
13	1	Copper washer
14	1	High-pressure grease delivery hose
15	1	Cross-headed screw
16	1	Hose holder
17	8	Screw, with washer
18	1	Stand (right)
19	1	Housing (right)
20	1	Coupler cap
21	1	Precision machined coupler

Tab. 12.-1: Overview of components for Fig. 12.-1

## 13. Accu charger for Li-Io accu 20 V



### WARNING

#### Risk of personal injury due to electric shock!

- Use only the specified rechargeable accu (18 051 100) included with this device for the charger. Charger also for (18 051 101). Other types of accus can burst, cause personal injury and property damage.
- Use only the specified charger to charge the accu. The charger and the accu were designed specifically for common use.

## 14. Safety instructions for the accu charger



### WARNING

#### Risk of injury and property damage due to improper handling

- Read all instructions and warnings on the charger and accu before using the charger.
- Read and observe the warning notes in this manual.

**WARNING****Risk of injuries by burns and electric shocks**

- **Do not** let any liquid enter in the charger, otherwise this may lead to electric shocks.
- Before cleaning the charger, disconnect the charger's power plug from the mains.
- Take care that the charger is not exposed to rain or snow.
- To disconnect the charger from the power source, always pull the plug and never the cable. This will reduce the risk to damage the plug and the cable.
- Lay the power cable so that no one can step on or trip over it.
- An extension cable should only be used if it is absolutely necessary. An unsuitable extension cable may lead to a fire or can cause dangerous injuries by an electric shock.
- Do not put any objects on the charger and do not place the charger on a smooth surface, because otherwise the air slots could be blocked and the device could overheat. Keep the device away from heat sources. The charger features air slots at the top and at the bottom of the housing.
- Do not operate the charger if it has suffered hard impacts, has fallen down or is damaged in any way.
- The charger is not allowed to be disassembled. Bring the charger to an authorized service center for maintenance or repair.
- A damaged power cable must be replaced by the manufacturer, a service center or a qualified person.
- The charger is designed for operation at a standard mains voltage of 230 V. The charger is not to be operated at any other voltage.

## 15. Repair / Service

The accu grease gun has been developed and produced according to the highest quality standards. Should a problem develop, despite of all quality controls, please contact our customer service:

**PRESSOL Schmiergeräte GmbH**

Tel +49 9462 17-216

Fax +49 9462 1063

service@pressol.com

## 16. Disposal

The operating company is responsible for the proper disposal of the accu grease gun.

Hereby, the industry-specific and local regulations must be observed when disposing of the different materials.

Only a qualified personnel is authorized to disassemble and dispose of the accu grease gun.

## 17. Transport

Transport the device only in the carrying case intended and supplied for that purpose.

## 18. EC Declaration of Conformity



Manufacturer:

**Pressol Schmiergeräte GmbH**

Parkstraße 7

93167 Falkenstein

Declares under his sole responsibility that the machine:

<b>Model type</b>	<b>Accu Grease Gun 18 051</b>
Electromotor voltage	20 V
Weight without fat	3,6 kg
Function	The grease gun is suitable for pressing greases up to the viscosity class NLGI 2 at a temperature of 20 °C.
Complies with all relevant provisions of the following Directive:	
EC Directives	2006/42/EG Machinery Directive 2014/35/EU Low Voltage Directive
Applicable standards	DIN 1283

Authorized representative for the compilation of the technical documentation:

Name: Maria Gross  
Address: Pressol Schmiergeräte GmbH  
Parkstraße 7  
93167 Falkenstein / Deutschland  
Phone: +49 9462 17-218

Pressol Schmiergeräte GmbH

Falkenstein, 31.08.2018

Dipl.-Ing. Rudolf Schlenker

(Managing Director))

**Pressol Schmiergeräte GmbH**

Parkstraße 7

93167 Falkenstein | Germany

Tel. +49 9462 17-0

Fax +49 9462 17-208

[info@pressol.com](mailto:info@pressol.com)

[www.pressol.com](http://www.pressol.com)

